



NELO



FOR MY FUTURE

Congratulations, you just acquired an incredible boat.
We are extremely proud on having developed this amazing
product and we hope it exceeds your expectations.

Thanks for trusting our work!

PADDLER ID

First Name _____

Surname _____

Date of Birth _____

Country _____

Best Results _____

1. BOAT ID / PADDLER ID
2. MY NELO
3. KAYAK
4. FITTINGS
5. CANOE
6. CANOE FITTINGS
7. ACCESSORIES
8. WARRANTY
9. MAINTENANCE
10. ABOUT US
11. SHOP



My Nelo is your home for all Nelo related. A single place for all your Nelo products and services.

Besides having all the info about your boats, MyNelo offers lots of tools to improve your boat care, the way you use your boat, logistics, and many others.

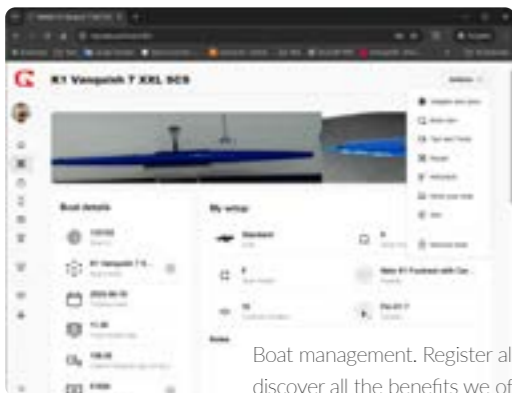

Boat management. Register all your boats and discover all the benefits we offer. Discover how you can take the most out of your boats, how to care for it and find upgrades.
Boat setup. Save all your setups for future reference.
Boat history. When was your boat made, by whom, what were its previous owners.

Always wanted to understand every detail of your favorite paddlers performance during races? Analyse their progress, meter by meter, on the most demanding events of them all.

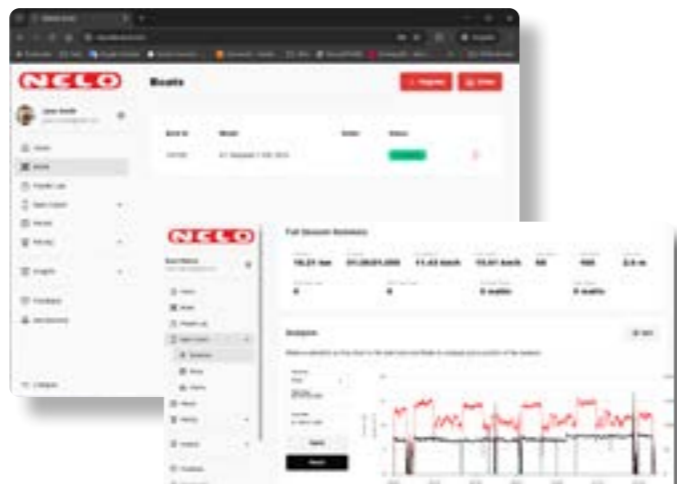

Analyze your training sessions made with the Nelo Coach companion app.
Partner with the Nelo Motion Sensor for improved accuracy.

Discover our Nelo Membership plans. Price discounts. Early access. Exclusive deals. Nelo has four membership tiers, each with increasing benefits and advantages.

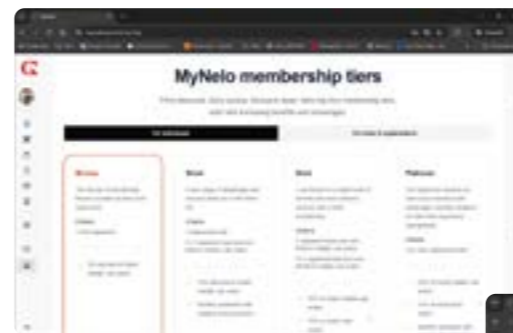

Always wanted to understand every detail of your favorite paddlers performance during races? Analyse their progress, meter by meter, on the most demanding events of them all.



Nelo Smart Tag

A digital ID embedded straight into your boat, permanent and unchangeable. Use your phone to read it and access all the boat's info and proof of authenticity and ownership.



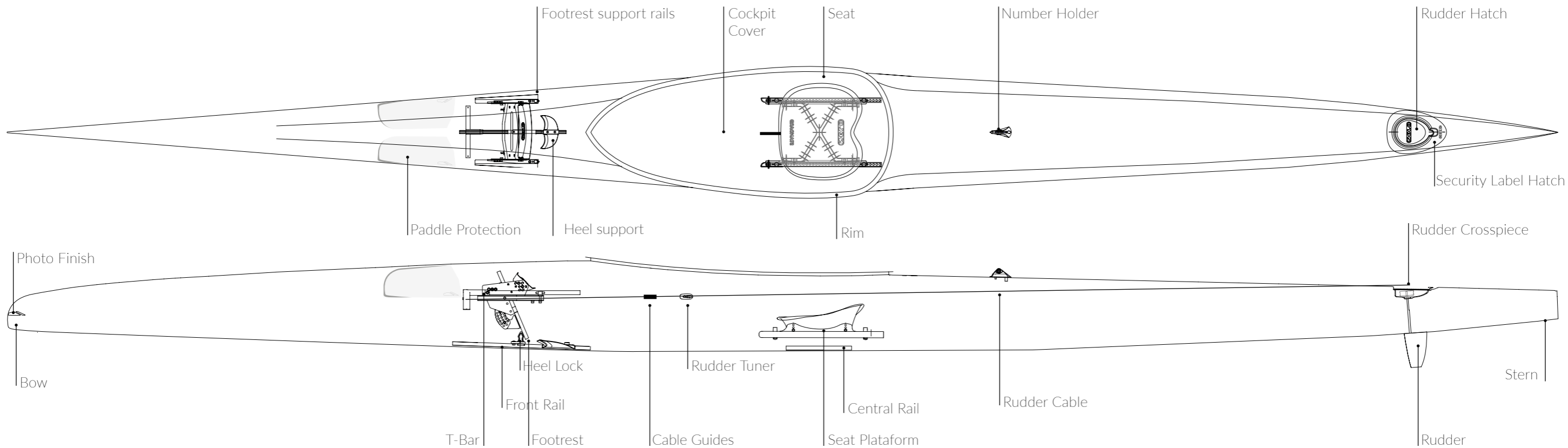

BOAT LAYUP

	Construction	Sport	Colour	Fittings	Trim Weights	K1	K2	K4
WWR	Carbon/Kevlar Epoxy Vacuum	River	1	Standard	N	10 kg	16 kg	-
F	Carbon Foam Epoxy Vacuum Heat Cured	Sprint	1	Standard	N	11 kg	17 kg	-
G	Extra Carbon Foam Epoxy Vacuum Heat Cured	Sprint	1	Standard	N	11 kg	17 kg	28 kg
SCS *	Solid Composite System	Sprint	3	Extra	Y	11 kg	17 kg	28 kg
E *	Carbon/Kevlar Vacuum Heat Cured	Marathon	2	Extra	N	7 kg	11 kg	-
FC	Full Carbon	Sprint	0	Extra	Y	11 kg	17 kg	28 kg
PREPREG	100% Carbon Fiber	Sprint	0	Extra	N	11 kg	17 kg	28 kg

0. Clear Carbon.

1. Standard Color, hull with only one color available.

2. Designs and colors available, but some restrictions due to the final weight of the boat.

3. Complex Designs and Colors available.

*Extra: Standard Fittings and Includes Cover and Weights.

MODEL

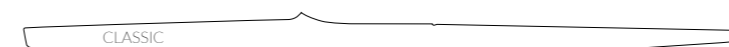

4 to be even more versatile.



5 to become smoother and balanced



7 to become sharper and faster



28 faster and more consistent performance

ATHLETE WEIGHT

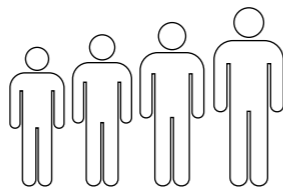

	1,5m > 6"1/4	1,6m 6"1/4 - 6"1/2	1,7m 6"3/4 - 7"	1,9m 7"1/2 - 7"3/4	2m 8"	2m< 8"<
50-54kg 110-120lb	S	S	M			
55-59kg 121-131lb	S	S	M			
60-64kg 132-142lb	S	S	M			
65-69kg 143-153lb	M	M	ML	XXL	XXL	
70-74kg 154-164lb		ML	ML	XXL	XXL	
75-79kg 165-175lb		L	L	XXL	XXL	XXXL = MOSKITO
80-84kg 176-186lb		L	L	XXL	XXL	XXXL = MOSKITO
85-89kg 187-197lb			XXL	XXL	XXL	XXXL = MOSKITO
90-94kg 198-208lb			XXL	XXL	XXL	XXXL = MOSKITO
95-99kg 209-219lb				XXXL = MOSKITO	XXXL = MOSKITO	XXXL = MOSKITO
100kg< 220lb<				XXXL = MOSKITO	XXXL = MOSKITO	XXXL = MOSKITO

TRIM - Optimum Static Rending

For standard weight

	s	M	ML	L	XXL	XXXL
4	*	*	*	*	*	*
5	31 mm	31 mm	28 mm	28 mm	*	*
7	31 mm	32 mm	43 mm	45 mm	50 mm	60 mm
						

X

Dimension measured 10cm from the bow, to the bottom of the hull.
The FC has 2 tanks in the front and back of the boat where 500 gr can be placed in each, allowing more options of trimming adjustment.

* To be disclosed

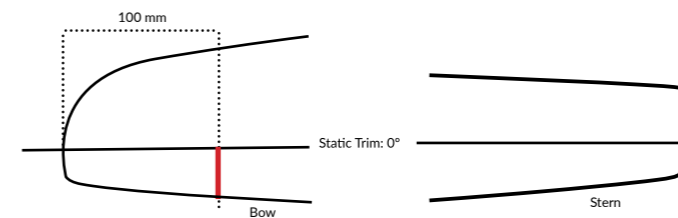

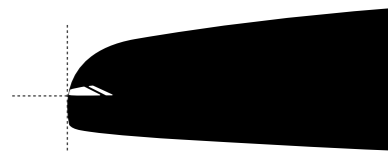



PHOTO FINISH

Make sure your bow is perfectly visible for the photo finish with these ultra thin high visibility decals.

The Photo finish decal are designed to use in canoes and kayaks to help ensure accurate race results and resolve close finishes. They serve as a visual reference point for recording the finish of a race, when the Photo Finish System is used, in situations where precision and fairness in determining the winner are crucial. 



PADDLE PROTECTION

Not all strokes are 100% perfect, specially when applying maximum power, and everyone wants to keep the boat as pristine as possible, we developed an adhesive transparent boat protection to discreetly protect the boat from hard blade hits. 

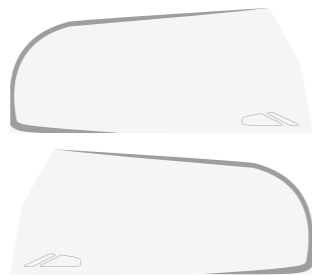

How to apply // Photo Finish // Paddle Protection

- 1 - Clean and dry the area well before applying the Paddle Protection .
- 2 - Peel the white paper backing off the sticker
- 3 - Slowly lower the sticker onto the boat and rub it in place firmly with a squeegee or credit card to avoid air bubbles.

KAYAK COCKPIT COVER

Waterproof cockpit cover. Protect your boat's interior from the elements, when stored and when travelling. Made for the Kayak line, so compatible with previous flat-water models. 



COCKPIT COVER WITH LOCK

New cover for kayak collars, more reinforced, made of more durable material and with the added feature of being able to be locked for greater security.

It is an extra product compatible with all flat-water models. 

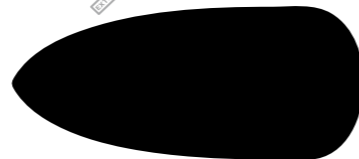

FRONT OR/AND LAND CENTRAL RAIL

This is fixed at the bottom of the boat, in front of the footrest or/and under the seat. It is specially designed to attach accessories like weight kits or heel support. It is 100% aluminum. 

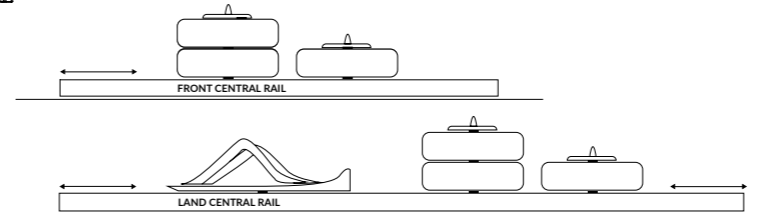
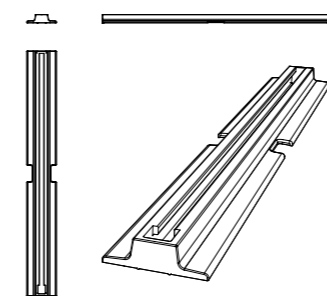

NELO WEIGHT KIT

Sustainable Nelo Weight System. It is derived from the reuse of material that is wasted during boat construction. Use it to trim your boat correctly and get best performance. 



HEEL SUPPORT

Give your heels a better support and lock them in place for an even better power transfer. Fits K1 and K2/K4 back positions. Carbon made. 

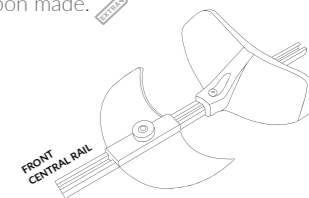

Nelo Heel Cale

Give your heels a better support and lock them in place for an even better power transfer. Fits K1 and K2/K4 back positions.

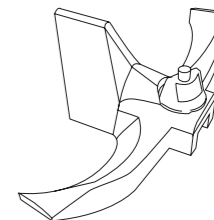

X

T-BAR CARBON 2025

A new fixed system, that can be undone and adjusted, if you still want you can drill and use the screw to secure your position. ©

<https://paddle-lab.com/t-bar-2025.html>

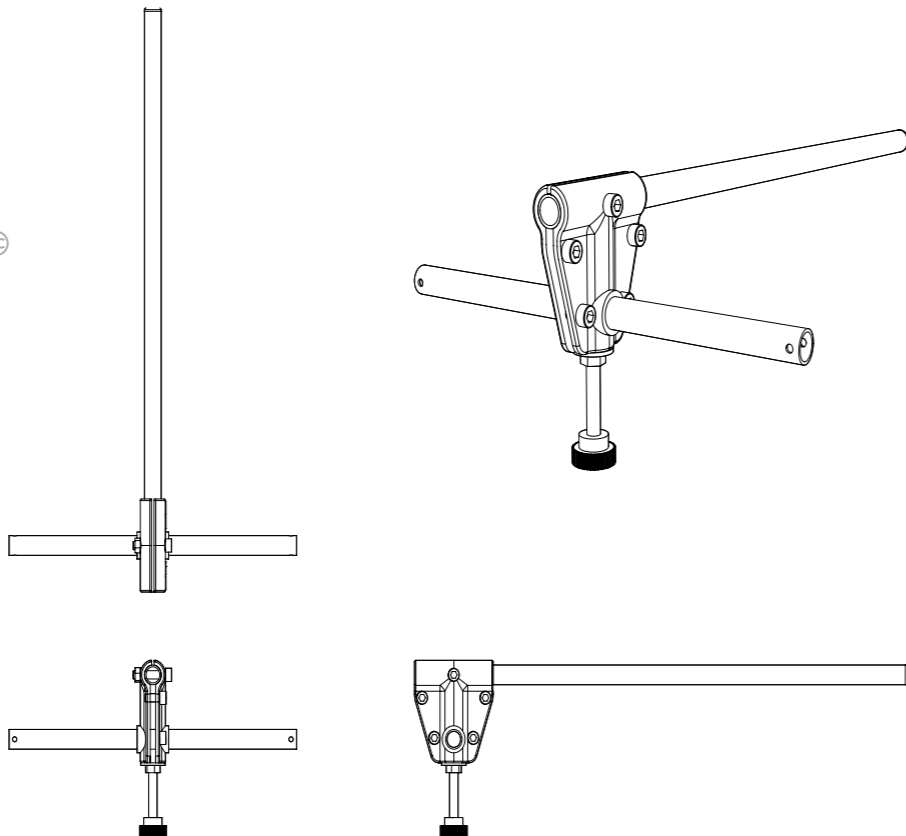
**FOOTREST** ©

The footrest is an essential piece of outfitting on your boat.

It provides a contact point where you can transfer the energy you get from your paddle into the movement of the kayak using all the power of your lower body. Nelo footrest offers a few configurable options such as angle and depth adjustments. And now it offers more strap options.

HOW TO REMOVE THE BOTTOM PLATE

By default, all footrests come configured with the full footplate. To remove it you just got to release four screws placed at the back of the footrest.



Foot Rest Strap	Contact Symmetrical	Heel Movement	Steering Ability
Carbon	1	2	1
Neoprene	3	3	2
Double Carbon/Neoprene	2	1	3
Double Neoprene	3	1	3

Less - 1 - 2 - 3 - More

Maratona Pedais Strap Carbono Strap Neoprene

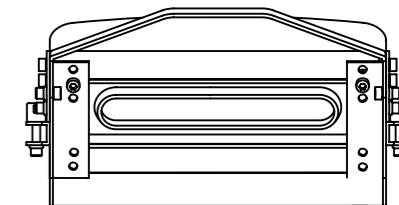
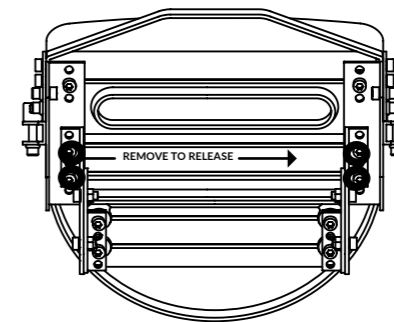
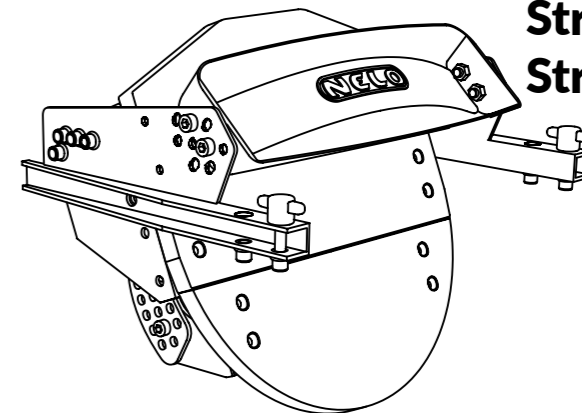

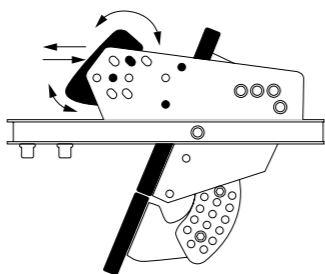
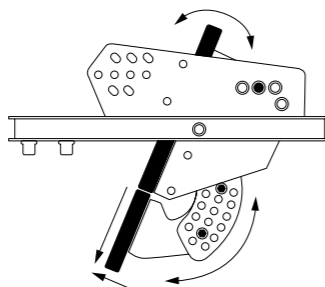
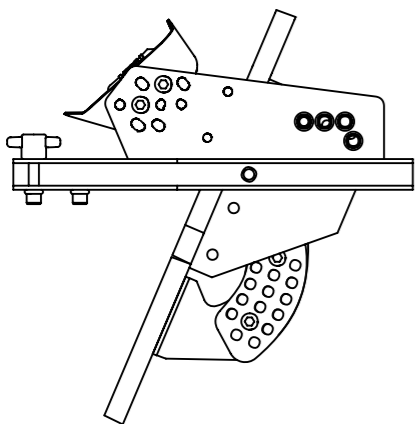

SETTING UP THE FOOTREST

Nelo footrests have many adjustable settings for total comfort and control. To set up you just need to loosen some screws and smoothly adjust the plates to the position that you want. When you finish remember to tighten the screws again.

SETTING UP PULL BAR OR FOOT STRAP

You can add a pull bar or a foot strap. You just have to fix it with four screws (two in each side) as the image suggests.

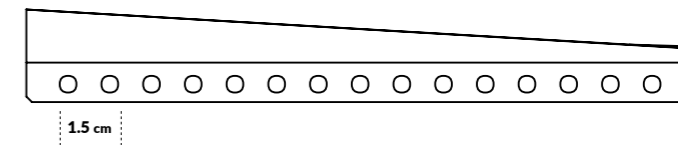
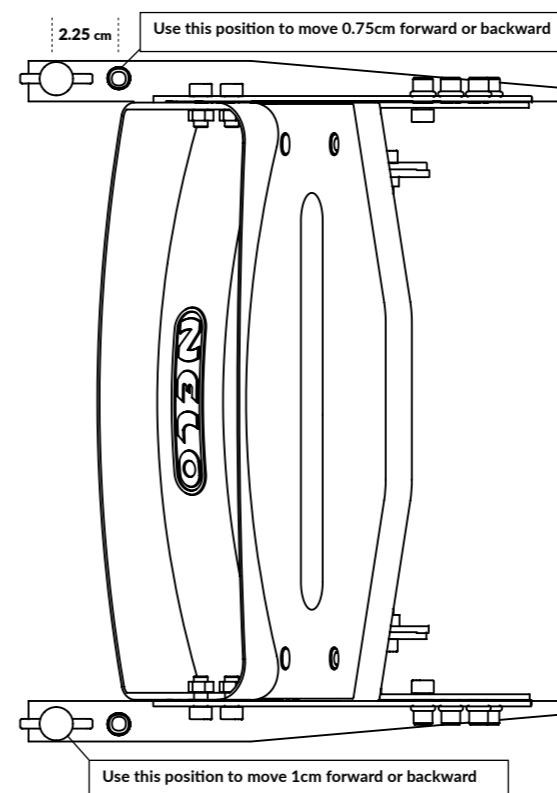

How to put the footrest on the boat

Footrest is fixed to the boat sliding it in the footrest rails and attaching two screws (one in each side) when it's on the right place¹.

¹See **HOW CAN I FIND THE RIGHT POSITION** tip.

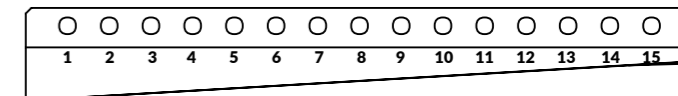

SEAT

Nelo offers five different seat models so you can choose which is more comfortable for you and your paddling style.

All models are configurable in many different height and angle positions.

All seat models

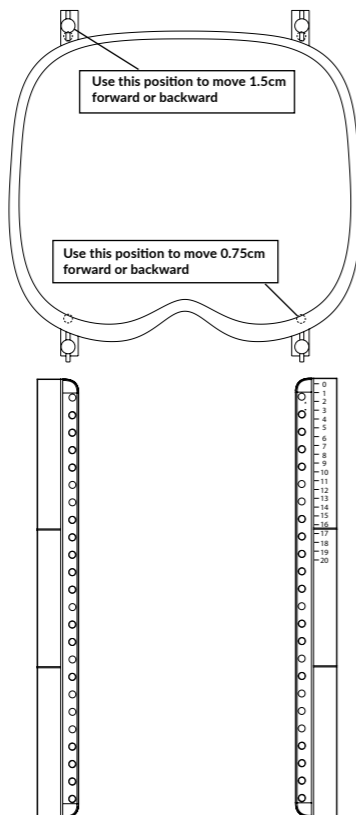
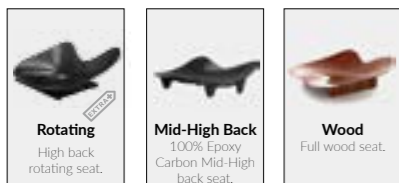

SEAT PLATFORM

It's where the seat will slide to be fixed at the right position.¹

¹See **HOW CAN I FIND THE RIGHT POSITION** tip.

How it works

Inserting in the Seat Platform

1- Slide the seat through the seat rails until your right paddling position¹.

¹See **HOW CAN I FIND THE RIGHT POSITION** tip.

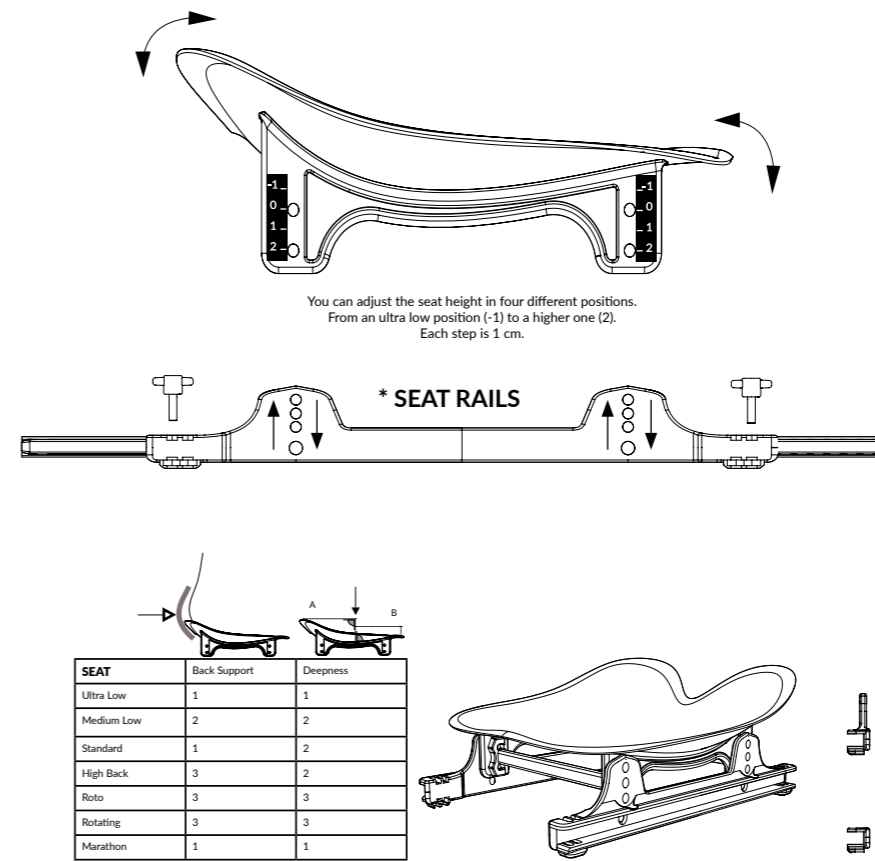

How it works

Adjusting the seat height and angle

- 1 - Remove your seat from your boat (if it's installed)
- 2 - The seat and the **seat rails*** have a few adjustable options
- 3 - Loosen the 4 screws that are attached to the seat and choose the right height and angle position
- 4 - When done tighten well the 4 screws again.
- 5 - Put the seat on the boat.

Seat Rails

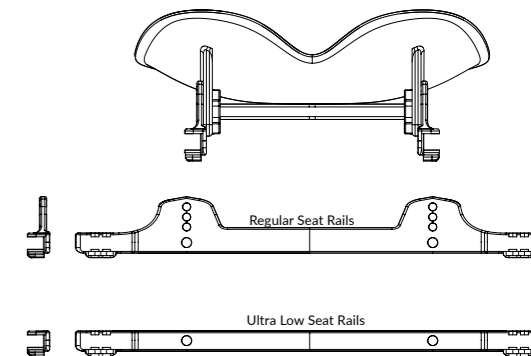

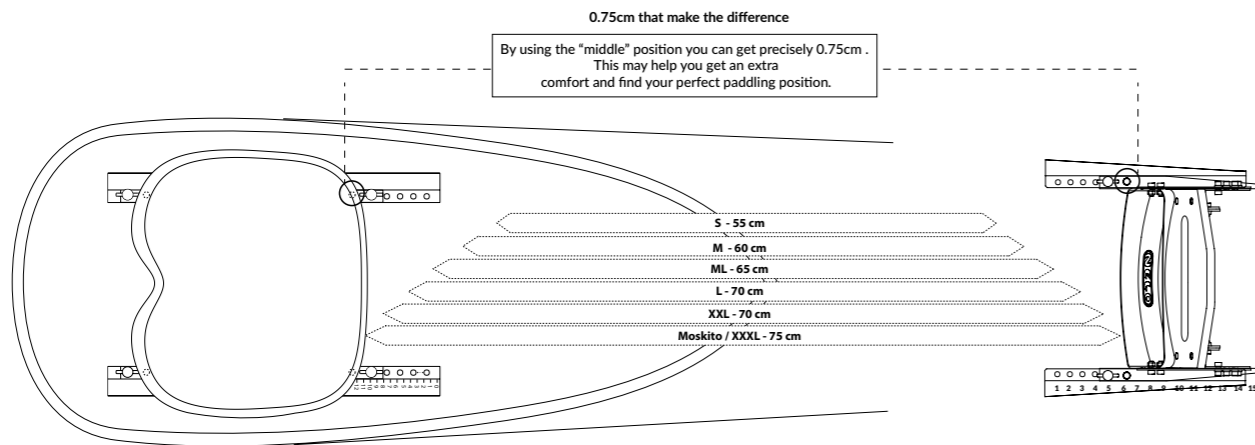
**TIP - THE SAME ADJUSTMENT**

Moving the seat and the footrest so it's equal. For example, if you move the seat one position to front, you need to do the same in the footrest to keep the same distance.

HOW TO FIND THE RIGHT POSITION**STEP ONE**

Start with the seat in the middle position. In the middle position the distance between the seat and the footrest varies between 65cm in the S model and 85cm in XXXL model.

STEP FOUR

Check the behaviour of the boat at competition speed. The bow should be just touching the water. In a stopped position the bow should be under water..

STEP TWO

Move the footrest to fit you. By using the full or "middle" adjustment positions you can get a large range of adjustments options.

STEP FIVE

You should move your seat and footrest together until your boat is performing as described at the previous point.

STEP THREE

The seat platform and the seat rails offers a wide interval of adjustment options too. This and the footrest settings allows the ideal configuration to the perfect paddling position.

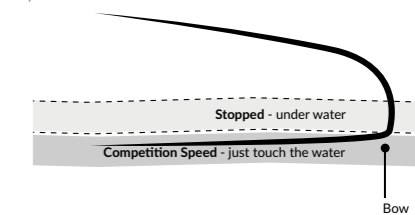
**NOTE**

This is just one of many methods of finding the best position, though it always changes slightly from person to person, but these are the basic rules.

RUDDER (Sprint | Marathon)

Currently with 3 options for boats we are also able to add even more options with a total of 7 different options for rudder possibilities. All these options allow the paddlers to take most out of their boat, by adapting it to their ergonomics and navigation preferences (see appendix). 

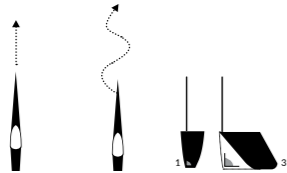

RUDDER	"Grip"	Turning Ability	Weed Deflection
Carbon 7	2	1	2
Carbon nr 2	3	3	1
Carbon nr 3	3	3	1
Fin n2	2	2	2
Fin n3	3	3	1
Cinco	1	2	3
Marathon	1	2	3

Less - 1 - 2 - 3 - More

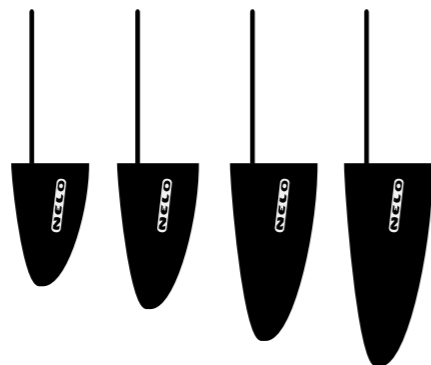

Rudder: Fin.

50% nylon - 50% fiber glass.
For Sprint use.

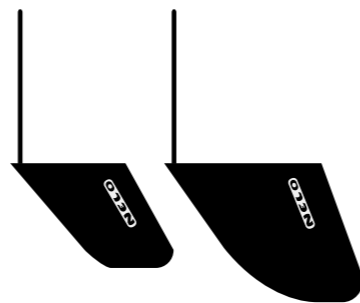

Marathon Rudder (6mm)

Specific for marathon. 100% Carbon
for impact resistance.

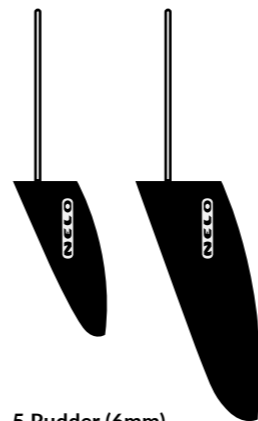

5 Rudder (6mm)

50% nylon - 50% fiber glass Shaft
diameter: 6 mm Shaft length, 13 cm

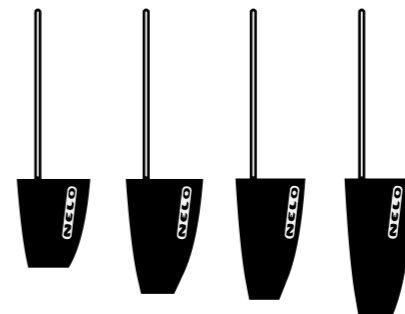

28 Rudder (6mm)

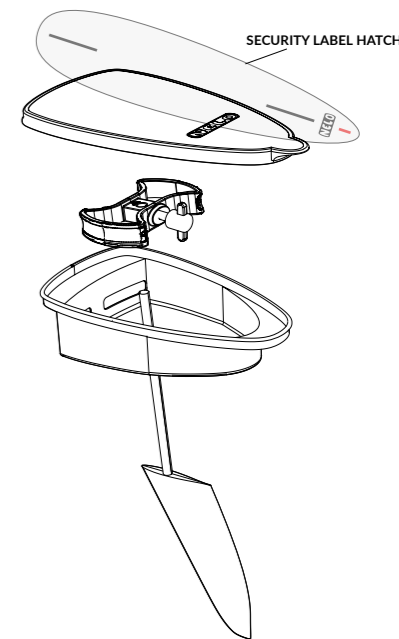

100% carbon. Ideal for sprint use.



How it works

- 1 - Insert the rudder through the hole in the hull.
- 2 - Insert the shaft into the crosspiece hole.
The arrow on the crosspiece should point forwards.
- 3 - It only fits in one way, so don't worry if it's ok. It will be.
- 4 - Tighten the rudder crosspiece screw.

RUDDER CROSSPIECE

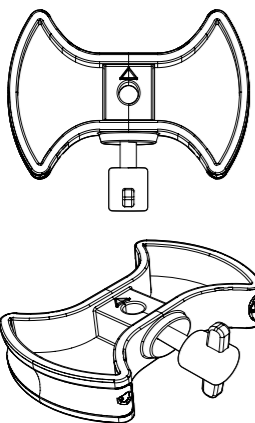

It's where the rudder cables are attached which makes it possible for the rudder to turn. It gives a sensitive, smoother control thanks to the new design.  



How it works

- 1 - Right and left rudder cables are attached to it with knots.
- 2 - Rudder enters in the one way channel and it's tightened with a simple screw.

CABLE GUIDES

Are used to guide the rudder cables to the crosspiece. They are low friction so you can have a smooth boat control.  

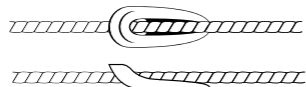

RUDDER CABLES

The rudder cables make the connection between T-Bar and Rudder Crosspiece and allows the rudder to work, so your boat will turn correctly. 



RUDDER ADJUSTING SYSTEM

It is used to tighten the rudder cables, in a quick way, which allows the rudder to turn better. 

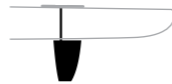

1. Hold rudder straight



2. Adjust the stretchers



3. Until t-bar stands straight at the middle

How it works

Thanks to its easy pulling system you just need to pull to tighten or extend the rudder cables until they are as you want.

SECURITY LABEL HATCH

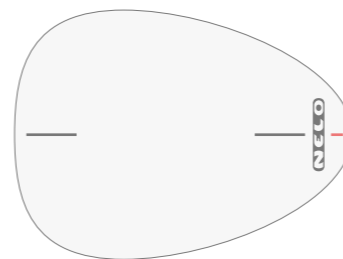

We have developed a transparent adhesive protective film for the rudder cover. It provides added safety and protection. 



How to apply

- 1 - Clean and dry the area well before applying the Paddle Protection .
- 2 - Peel the white paper backing off the sticker
- 3 - Slowly lower the sticker onto the boat and rub it in place firmly with a squeegee or credit card to avoid air bubbles.

NUMBER HOLDER

This is where you place the competition number or lane number. It is made of 100% plastic and fixed only with two simple nuts.  

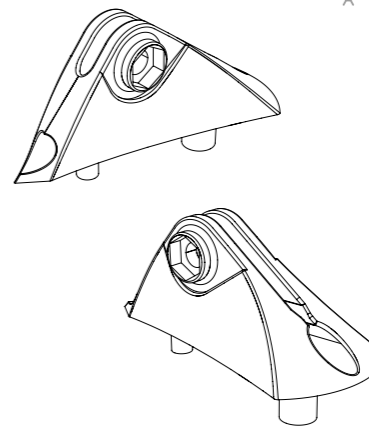

How to replace

- 1- Remove old Number Holder from your boat unscrewing old screws.
- 2 - Put the new Number Holder at the same place and tighten the new nuts.

NOT JUST A NUMBER HOLDER

You can use the Number Holder to fix some useful tools.

The number holder it's compatible with GoPro mount system so you can place here, for example, your camera or a Nelo Waterproof Phone Bag.

It's also a comfortable bed for your rudder when you're in travel.

Be creative with the Number Holder

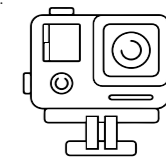

Nelo Waterproof Phone Bag available at shop.nelo.eu

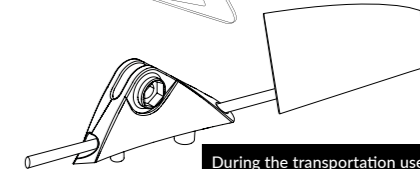
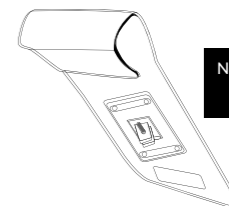

During the transportation use it to keep your rudder safe.

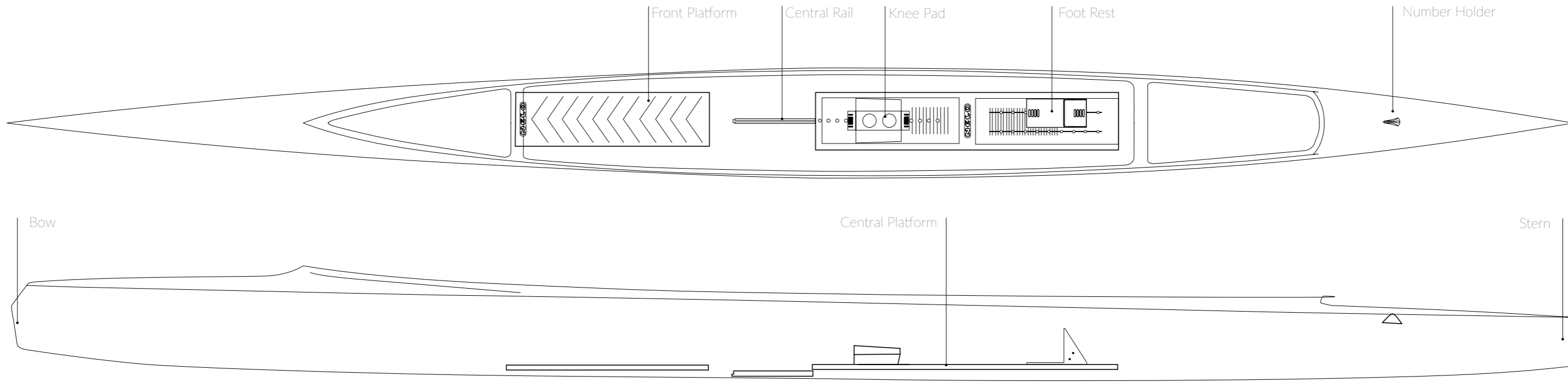



Boat Layout

	Construction	Sport	Colour	Fittings	Trim Weights	C1	C2	C4
WWR	Carbon/Kevlar Epoxy Vacuum	River	1	Standard	N	13 Kg	-	-
F	Carbon Foam Epoxy Vacuum Heat Cured	Sprint	1	Standard	N	13 Kg	18 Kg	-
G	Extra Carbon Foam Epoxy Vacuum Heat Cured	Sprint	1	Standard	N	13 Kg	18 Kg	28 Kg
SCS *	Solid Composite System	Sprint	3	Extra	Y	13 Kg	18 Kg	28 Kg
E *	Carbon/Kevlar Vacuum Heat Cured	Marathon	2	Extra	N	9 Kg	15 Kg	-
FC	Full Carbon	Sprint	0	Extra	Y	13 Kg	18 Kg	-
PREPREG	100% Carbon Fiber	Sprint	0	Extra	Y	13 Kg	18 Kg	-

0. Clear Carbon.
 1. Standard Color, hull with only one color available.
 2. Designs and colors available, but some restrictions due to the final weight of the boat.
 3. Complex Designs and Colors available.

*Extra: Standard Fittings and Includes Cover and Weights.

ATHLETE WEIGHT

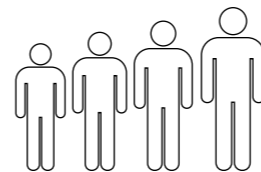

	1,5m ≥ 6'1/4"	1,6m 6'1/4" - 6'1/2"	1,7m 6'3/4" - 7"	1,9m 7'1/2" - 7'3/4"	2m < 8' <
50-54kg 110-120lb	S	S	M		
55-59kg 121-131lb	S	S	M		
60-64kg 132-142lb	S	S	M		
65-69kg 143-153lb	M	M	L	XL	XXL
70-74kg 154-164lb		L	L	XL	XXL
75-79kg 165-175lb		L	L	XL	XXL
80-84kg 176-186lb		XL	XL	XL	XXL
85-89kg 187-197lb			XXL	XXL	XXL
90-94kg 198-208lb			XXL	XXL	XXL
95-99kg 209-219lb				XXL	XXL
100kg < 220lb <				XXL	XXL

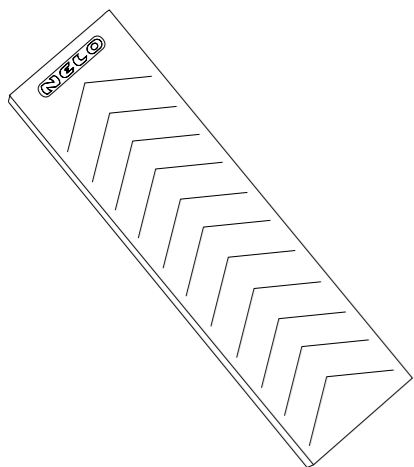

FRONT PLATFORM

It's where your front foot will be and it's non-slip for a better grip and extra-comfort during all stroke phases. 

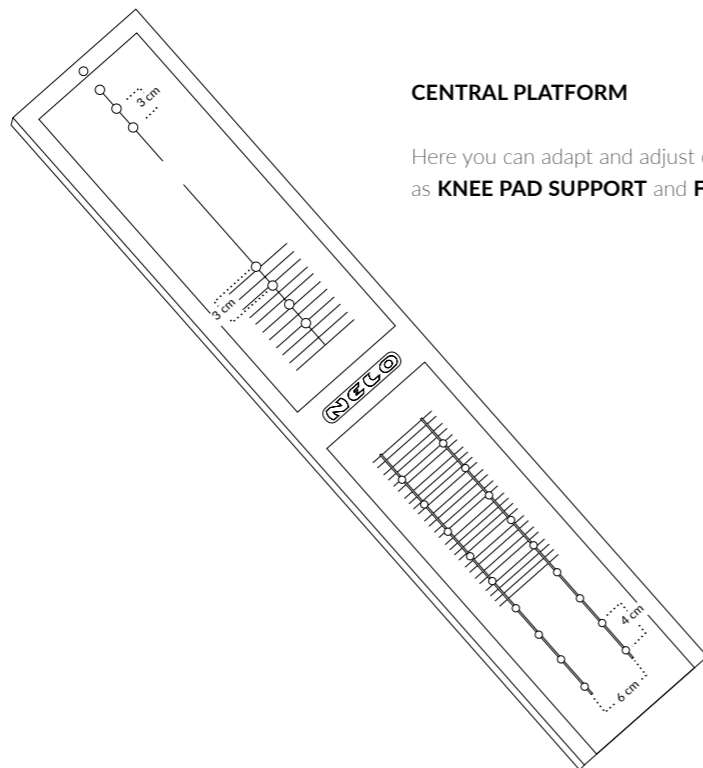

CENTRAL PLATFORM

Here you can adapt and adjust other fittings as **KNEE PAD SUPPORT** and **FOOTREST**. 

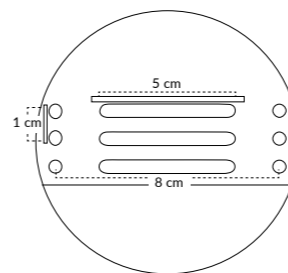

FOOT REST

Aluminium foot rest for all Nelo canoe models. Like the knee pad, it is plenty of options for easy positioning. 

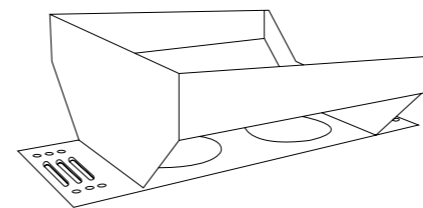

KNEE PAD SUPPORT

This is a aluminium holder for knee pad. Fully supports the pad with plenty of options for easy positioning. 

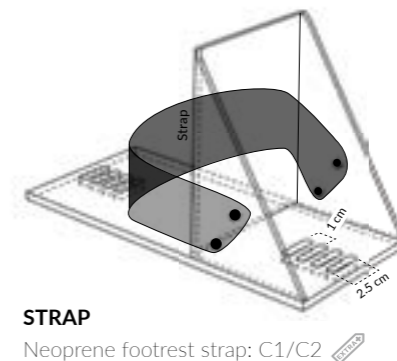

STRAP

Neoprene footrest strap: C1/C2 

A PLENTY OF POSITIONING OPTIONS

The Nelo Canoe platform fittings offers different positioning options so you can adjust you knee and foot inperfection. perfection.



How it works

Thanks to its easy adjustable system you just need to find your ideal position as the knee pad and footrest angle and finally tighten the screws.

BOAT COVER

K1 Cover in a light, breathable fabric. Protects your boat during transport and storage. 

**NEW BOAT COVER**

New protective cover with built-in support backpack, new color, new exclusive design for this model.

More durable and adjustable material, and with less bulk for storage and transport. 

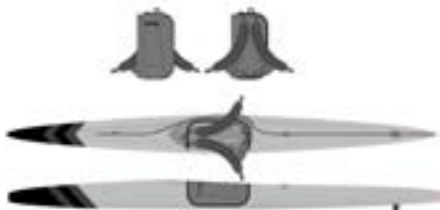
**SCREWS**

Screws for Footrests and Seats Length: 22mm. 

**STEERING STRETCHERS**

Pair of steering stretchers. It is used to tight the rudder cables, in a quick way, which allows the rudder to turn better. It has a tightening tab to facilitate the procedure. 

**NELO STICKERS**

Pair of Nelo Stickers. Length 17 cm. 

**SHOULDER BAG**

The NELO shoulder bag is an exclusive accessory for the 28 model; it is shipped inside the boat, along with the manual and some boat accessories. 

**NELO CARBON BACKPACK**

Comfortable backpack, made with leftover material from the kayak and scraps of fabric from the covers. This product can be personalized with a name sticker, and designs are also possible, just like on boats. 

<https://paddle-lab.com/nelo-carbon-backpack.html>

**NELO WATER BOTTLE AND SUPPORT**

Metal Nelo drink bottle can be reused as many times as desired, making it eco-friendly that can avoid the consumption of single-use plastic drinking containers. This water bottle is perfect for outdoor sports such as paddling. It has a foldable mouthpiece and lid hanger. ALUMINIUM Dimensions: 7.00 x 15.00 cm.

SUPPORT

This boat bottle cage lets you access easily your water bottle. It's designed to fit on your boat rail. 2 screws included. 

**MICROFIBER CLOTH**

Microfiber cloths are cleaning tools made of ultra-fine fibers that use a positive electrostatic charge to trap dirt, grease, and bacteria. They can be used effectively with just water on a variety of surfaces, ideal for the surface of your boat. 

**How to use**

1. Use latex gloves during the cleaning process. Rinse the boat with fresh water.
2. Spray the boat's surface with Cillit Bang and wipe the entire boat with a microfiber cloth.
3. Rinse the boat thoroughly with fresh water again to remove all the chemicals. Let it air dry or wipe off excess water with a clean microfiber cloth.

NELO PADDLE GRIP

Nelo and Ach. Brito have developed a hand-wash soap based on pumice that prevents your hands from slipping off your paddle. 

**MINI BOAT STAND 1 pair.**

This elegant and portable boat stand is the perfect companion for your boat.

Easily transportable it will set your boat at over 40cm high so you keep it far from the ground when it's out of the water. 

<https://paddle-lab.com/mini-boat-stand.html>



NELO KAYAKS WARRANTY TERMS

This document sets out the sole and limited warranty which Nelo is giving on Kayaks. This warranty should be reviewed carefully, together with the User Manual.

BASIC WARRANTY

Nelo warrants the boat, except for excluded items, and when properly used, will be free of defects in materials or workmanship for a period of 24 months from the moment it has been assessed for damages due to transport. Validation must be done within 30 days, time when the warranty will be automatically validated.

Warranty on other Composite Parts

The following parts: Seat, Foot Rest, Rudder, Hatch and Hold Number warranted to be free of defects in materials or workmanship for a period of 24 months starting at the same time as the boat's warranty. Warranty is valid only when the products are properly used.

Transfer of Warranty

If you sell the boat during warranty period, your buyer may receive the benefit of the balance of the warranty by agreeing to be bound by its terms.

Authorized Dealers

To obtain a list or confirm that you are dealing with an Authorized Dealer contact Nelo.

Excluded Items

Nelo gives no warranty of the following:

- Any components manufactured other than by Nelo.

- **Sun damage** - If the boat is exposed to the sun for long periods of time it may cause some damages to the composite material. In that case, the warranty shall be voided.

- **Osmotic Blistering:** The primary factor in the design of the boat is performance. As a result, surface coatings and the thickness were chosen to maximise its potential performance. If the boat is left in a wet cover, in very humid environment or not properly dried, osmosis warranty shall be voided.

- **Varnished boats:** boats with complex designs usually need a layer of varnish as a final coating. This material doesn't have the same properties as regular gel coat, thus needing some extra care. Not observing the following rules will void the warranty:

- Don't apply solvents
- Avoid contact with abrasives
- Have extra care when handling not to bump it hard
- Use a cover whenever possible
- Do not tie it down too tight
- Minor discrepancies in the desired design and small cosmetic errors do not entitle you to deductions or returns.

- **Collision damage** - damages resultants from collisions or misuse are not covered by warranty.

- **Salt oxidation** - If the boat is used on salt water and isn't regularly washed after use that may oxidate some boat parts. In that case, the warranty shall be voided..

All repairs not made by Nelo or Authorized Persons are not covered under this warranty.

Proper Use

All of the above warranty clauses are expressly conditioned upon the proper use of the boat. This means that you follow the indications reviewed at the manuals and perform suggested maintenance to the boat as recommended in it.

Warranty Claims

In order to make a claim under these clauses you must do the following:

- Report the defect to Nelo within thirty days of discovering it. The report must identify the Serial Number, date of delivery and photos.
- Make the boat available for inspection if requested.
- Make the boat available, when required, for repairs by Nelo or Authorized Persons.
- Nelo reserves the right to choose an outside technician to do the repair. All warranty requests must be accompanied by a detailed written estimate prior to beginning any warranty work and it must be approved by Nelo.

Repair or Replacement

Nelo shall perform its obligations under the terms of this warranty at its option either repairing or replacing defective part or component. Parts or components do not extend the warranty period, but these repairs or replacements will be covered for the balance of the warranty period.

Exclusion of Implied Warranties

The foregoing warranty is intended to be in lieu of all other warranties express or implied. NELO disclaims all implied warranties including warranties of merchantability and fitness for a particular purpose. In such jurisdictions these exclusions are limited the NELO expressly limits any implied warranties to the greatest extent and to the shortest duration allowed by law.

Limitation of Coverage

Nelo or Official Nelo Dealers only provide warranty service in a 300 Km radius within the same landmass, unless stated otherwise by the local dealer.

Limitation of Damages

Nelo disclaims any liability to you for incidental, consequential or indirect damages, including loss of time, loss of use, loss of revenue, travel expenses, transportation charges, food or lodging charges or loss of personal property. In such jurisdictions that these exclusions are limited to Nelo expressly limits its liability for damages to the greatest extent allowed by law.

Whole Agreement This warranty is the sole warranty given by Nelo. Any questions about the warranty should be directed at nelo@nelo.eu.

Nelo Maintenance Guidelines

One of the big advantages of composites is that they don't require much maintenance. Nevertheless, there are a few rules that can extend your boat's life.

Do not put it in the sun for long periods.

Composites materials may deform when exposed to high temperatures for long periods.

Do not tight it too strongly in the racks.

Composites materials are strong and resistant but there's no need to tight it too strongly into the racks.

Only allow professionals to repair your boat.

Only professionals know the best way to repair your boat.

Never store or transport it inside the cover if the boat is not well dry.

Composites materials may change some properties when are closed wet.

Wash your boat after use it in salt water.

Salt water, as well brackish or polluted water may oxidize and damage your boat components. A quick wash of the moving parts as footrests, seats and rudder system keeps them clean and working perfectly.

Avoid direct collision with hard objects.

That may damage and break your boat surface.



Nelo is the leading company in top performance kayaks and canoes and the major innovator in canoeing, from boat design to services and technology. This know-how poured into new areas and Nelo have now a strong footing in all paddle related sports, from Rowing to Stand Up Paddle, while still developing and producing strong composite shells for other sports and showing great versatility in the production of all kind of composite sport equipment under other brands.

The company was created in 1978 by Manuel Ramos, a former paddler himself, and is now located in Vila do Conde, Portugal. The factory has an area of 20.000m2 where 150 employees work, a big percent of which does, or has done, kayaking.

Innovation is a big part of our DNA, constantly improving and developing new concepts and ideas. All our models are designed and conceived by us, with the help of professional personnel and techniques.

With a network of 40 dealers, Nelo covers the globe and sells to over 100 countries.

FIND THOSE AND MANY OTHER PARTS AT OUR SHOP!



Nelo Training Centers + Coaching Services

Nelo's goal is always to get as close as possible to the athletes, to better understand their wishes and needs.

Nelo has at the moment three training centers, offering a full coverage to the 3 international airports in Portugal. This new combination assures that among this portfolio you can for sure find a suitable solution for your camp, testing boat or just for an active holiday.

<https://www.nelo.eu/nelo-training-centers/>

Nelo Testing Center/Experience our boats on the water before you choose your perfect fit!

<https://www.nelo.eu/nelo-testing-center/>



For those who don't want or can't take their boats to the competitions

How It Works

Nelo Rental Pro is a service aimed for teams and athletes competing at races serviced by Nelo Tour, that don't want or can't take their own boats to the venue and therefore need to rent them.

<https://www.nelo.eu/nelo-rental/>

Email: nelo@nelo.eu



Repair Center

Your Boat in Good Hands

Although composite boats such as ours are very sturdy and can last a life, they are not indestructible and some unexpected trauma may cause damage. Fortunately, they are repairable. So, if your boat needs assistance, either from regular usage that cause some tear and wear, or from more serious damage, our technical personnel at the Nelo Repairing Centers is specially trained to help and solve these kinds of problems. Before submitting a boat for repair, you should register it first.

Email: nelo@nelo.eu



At **Paddle Sports Design** we believe that the paddler should be able to express their uniqueness through their equipment, without the need for any specialized designing skills.

We differentiate ourselves through a combination of unique designs and styles merged with unequalled standards of quality and authenticity. Our selections serve amateur practitioners and professional athletes alike.

<https://paddlesportsdesign.com/>

Email: info@paddlesportsdesign.com



Our goal at **Paddle Lab** is to provide a hub for all paddle sports related gear, from clothing to parts and accessories.

<https://paddle-lab.com/>

Email: sales@paddle-lab.com

SUSTAINABILITY



Sustainability was the foundation of this new line in order to minimize the impacts of the entire process, by having a responsible choice of feedstocks, an efficient production and with correct waste management.

All plastic in our boats is 100% certified, recovered from the ocean, a first step towards increasing the circular economy of our products.

<https://www.nelo.eu/sustainability/>

ARGENTINA
ASTILLERO SIOUX
Phone: 0059847323915
Email: gonzalougolini@gmail.com
Web: http://www.siooux.com.uy
Contact: Gonzalo Ugolini

AUSTRALIA
NELO AUSTRALIA
Phone: +61412444461
Email: nigel@neloaustralia.com.au
Web: http://www.neloaustralia.com.au/

AUSTRIA
kayak-connection
Phone: +43 664 7640920
Email: office@kayak-connection.at
Web: http://www.kayak-connection.at/
Contact: Petra Luckeneder

BELARUS
LANA LTD
Phone: +375 29 6527901
Email: igor-lana@tut.by
Contact: Igor Laptenok

BELGIUM
NELO BELGIUM
Phone: +32 (0) 486717936
Email: bob.maesen@yahoo.com
Contact: Bob Maesen

BOSNIA
KAYAK HOUSE DOO
Phone: +381611359757
Email: office@kayakhouse.rs
Web: http://www.kayakhouse.rs/
Contact: Milenko Nasagacin

BRASIL
J D C DAL MOLIN E CIA LTDA
Phone: +55 45 9 9992 7447
Email: julianoane@hotmail.com
Contact: Juliano Crai

BULGARIA
DM STARS LTD
Phone: +359 888 763 500
Email: nelobulgaria@yahoo.com
Web: http://bulgaria.nelo.eu/

CANADA
NELO CANADA
Email: nelocanada@gmail.com
Web: http://www.nelocanada.ca
Contact: Scott

CHILE
POSEIDÓN
Phone: 056-9-50550396
Email: poseidon.fibra@hotmail.com
Contact: Alvaro Torres

CHINA
SHANGHAI PEI SHENG BOAT
Phone: +86 137 016 205 45
Email: sales@ps-boat.com
Contact: Zhu Pei Wen

COLOMBIA
KANOTEC
Phone: 300 6 53 93 21
Email: kanotec@hotmail.com
Contact: Edwin Amaya Serna

CZECH REPUBLIC
PETR MOKRY
Phone: +420 604 236 269
Email: mokry@csstv.cz
Contact: Petr Mokry

DENMARK
NELO DANMARK
Phone: +453 062 8810
Email: mail@nelodanmark.dk
Contact: Ole Torp

FINLAND
WELHONPESA Oy
Phone: +358 40 544 2501
Email: welho@enettilija.fi
Contact: Juhani Holmi

FRANCE
SARLI SURANYI
Phone: +33 667 508 232
Email: patrick.suranyi@wanadoo.fr
Web: http://www.kayak-online.fr
Contact: Patrick Suranyi

GERMANY
NAUTICUS GMBH (I)
Phone: +49 176.61190069
Email: post@nauticus.de
Contact: Peter John

GREECE
ALL ABOUT SPORT
Phone: +30 210 482 9974
Email: aas@aasport.gr
Contact: Kyriakos Zaroulas

HONG KONG
HK KAYAK
Phone: +852 92014906
Email: hk.kayak@hotmail.com
Contact: Raymond Lo

HUNGARY
NELO HU
Phone: +36 703 752 475
Email: info@nelo.hu
Web: http://www.nelo.hu
Contact: Bartfalı Krisztian

INDIA
ANJANA INTERNATIONAL INDUSTRIES
Phone: +011-41613255
Email: rajanhanda@hotmail.com
Contact: Rajan Handa

IRELAND
GARY MAWER
Phone: +353 879 871 996
Email: garymawer@hotmail.com
Contact: Gary Mawer

ISRAEL
YAMIT V/S B LTD
Phone: +97235271777
Email: elian@yamitvysb.co.il
Web: http://www.yamitvysb.co.il/
Contact: Eitan Friedlander

ITALY
TEGYSPORT
Phone: +39 338 80 49 696
Email: tegy sport@tiscali.it
Contact: Teodoro Lapertosa

JAPAN
FLAT WATER Co.
Phone: +81 903 096 3712
Email: naoyu@edline.jp
Contact: Naoya Matsushiro

LATVIA
BRACA SPORT LITHUANIA
Phone: +370 699 27581
Email: braca-ll@braca-sport.com
Contact: Anunas Tomkevicius

LITHUANIA
BRACA SPORT LITHUANIA
Phone: +370 699 27581
Email: braca-ll@braca-sport.com
Contact: Anunas Tomkevicius

MACEDONIA
Kayak House Doo
Phone: +381611359757
Email: office@kayakhouse.rs
Web: http://www.kayakhouse.rs/
Contact: Milenko Nasagacin

MALAYSIA
NELO MALAYSIA
Email: nelomalaysia@gmail.com

MONTENEGRO
Kayak House Doo
Phone: +381611359757
Email: office@kayakhouse.rs
Web: http://www.kayakhouse.rs/
Contact: Milenko Nasagacin

NEW ZEALAND
IPADDLÉ
Phone: +64 9 273 0173 / +64 21 074 8485
Email: teran@iug.co.nz
Web: http://www.ipadlle.co.nz/
Contact: Terry Newsome

NORWAY
NELO NORGE AS
Phone: +47 97 96 76 69
Email: post@nelo.no
Web: http://www.nelo.no
Contact: Eirik Verås Larsen

POLAND
OLIMPIJCZYK BIS
Phone: +48 61 8 218 871
Email: pracharczyk@olimpijczyk.org
Web: http://www.olimpijczyk.org
Contact: Ireneusz Pracharczyk

ROMANIA
SC KAJAC NELO RO SRL
Phone: +40731672331
Email: loctavian_kajac@yahoo.com
Web: http://www.nelo.ro
Contact: Octavian Ispas

RUSSIAN FEDERATION
ANDREY DEMBIKOV (RU)
Phone: +7 985 776 64 59
Email: andrey@dembikov.ru
Contact: Andrey Dembikou

SERBIA
KAYAK HOUSE DOO
Phone: +381611359757
Email: office@kayakhouse.rs
Web: http://www.kayakhouse.rs/
Contact: Milenko Nasagacin

SINGAPORE
MOTIV ASIAN PTE LTD (SG)
Phone: +65 97211881
Email: clarencechualh@hotmail.com
Contact: Clarence Chualh

SLOVAKIA
Nelo Slovakia
Phone: +421904309913
Email: miromico@gmail.com
Web: http://www.neloslovakia.sk
Contact: Miroslav Mico

SOUTH AFRICA
AFRICAN KAYAK SOLUTIONS
Phone: +27 704331768
Email: Hptcanoekayaking@gmail.com
Contact: Craig Mustard

SOUTH KOREA
ON THE WATER
Phone: 010 3798 8374
Email: otw@8374onwater.com
Contact: Park yong-soo

SPAIN
NELO NAUTICA ESPAÑA, S.L.
Phone: + 34 687766561
Email: nelonauticaesp@hotmail.com
Web: http://www.neloespaha.com
Contact: Esteban Alonso

SWEDEN
DIETZ
Phone: +46 73 030 2992
Email: info@dietz.se
Web: http://www.dietz.se/
Contact: Christian Dietz

SWITZERLAND
SCHWARZER PADDEL
Phone: +41(0) 71 440 02 82
Email: info@schwarzer-paddel.com
Web: http://www.schwarzer-paddel.com/
Contact: Beat Hausmann

TAIWAN
SING BRIGHT INTERNATIONAL LTD
Phone: +886-7-380-5940
Email: evasport@ms27.hinet.net
Contact: Helena Hsu

THE NETHERLANDS
KAJAK CENTRUM AREND BLOEM
Phone: +31 75 62 188 05
Email: info@arendbloem.nl
Contact: Arend Bloem

UKRAINE
Nelo Ukraine
Phone: +380 95 860 86 41
Email: rost227@gmail.com
Web: nelo.prom.ua
Contact: Vvedenskyj Rostyslav

UNITED KINGDOM
Ultimate Kayaks
Phone: 07831698150
Email: sales@ultimatetkayaks.co.uk
Web: http://www.ultimatetkayaks.co.uk
Contact: Ivan Lawler

UNITED STATES
NELO NY
Phone: 917-841-7597, +1 (203) 731-4659
Web: http://www.oceanpaddlesportseast.com
Contact: Jim Hoffman, Mark Ceconi, Steve DelGuido

ELITE OCEANSPORTS
Nelo Slovakia
Phone: +1 843 224 7509
Email: mckengm@eliteoceansports.com
Web: http://www.eliteoceansports.com/
Contact: Mark McKenzie

PADDLE CALIFORNIA
Phone: +1(619)796-8048
Email: info@paddelcal.com
Web: http://www.paddelcal.com/
Contact: Michele Eray

SPRINT RESOURCES
Phone: +1.239.257.9245
Email: lan@sprintresources.com
Web: http://sprintresources.com/
Contact: lan Mack

URUGUAY
ASTILLERO SIOUX
Phone: 0059847323915
Email: gonzalougolini@gmail.com
Contact: Gonzalo Ugolini

VENEZUELA
SOLO DEPORTES, C.A.
Phone: +58 0414 5292977
Email: operaciones@solodeportes.net.ve
Contact: Regelio Ornelana

NELO

www.nelo.eu